



晶采光電科技股份有限公司
AMPIRE CO., LTD.

SPECIFICATIONS FOR LCD MODULE

CUSTOMER	
CUSTOMER PART NO.	
AMPIRE PART NO.	AM-800600C4TMQW-TA3H-B
APPROVED BY	
DATE	

- Approved For Specifications
 Approved For Specifications & Sample

AMPIRE CO., LTD.

4F., No.116, Sec. 1, Xintai 5th Rd., Xizhi Dist., New Taipei City 221, Taiwan (R.O.C.)

22181 新北市 汐止區 新台五路一段 116 號4 樓(東方科學園區A 棟)

TEL:886-2-26967269 , FAX:886-2-26967196 or 26967270

APPROVED BY	CHECKED BY	ORGANIZED BY

RECORD OF REVISION

Revision Date	Page	Contents	Editor
2018/07/02	--	New Release	Mark

1. Features

8 inch Amorphous-TFT-LCD (Thin Film Transistor Liquid Crystal Display) module. This module is composed of a 8" TFT-LCD panel, LED backlight, LED driver unit ,Resistive Touch Panel and power circuit unit.

- (1) Construction: 8" a-Si TFT active matrix, White LED Backlight and LED driver unit.
- (2) Resolution (pixel): 800(R.G.B) X600
- (3) Number of the Colors : 262K colors (R , G , B 6 bit digital each)
- (4) LCD type : Transmissive , normally White
- (5) Interface: LVDS interface 20 pin
- (6) Power Supply Voltage: 3.3V for logic voltage, 5.0V for LED driver power voltage.
- (7) Viewing Direction: 6 O'clock (Gray Inversion)
- (8) LCM: [84TFT-800600C4TMQW02\(Please refer 2017PCN\)](#)
- (9) [New Resistive Touch Panel](#)

2. PHYSICAL SPECIFICATIONS

Item	Specifications	unit
LCD size	8 inch (Diagonal)	
Resolution	800 x 3(RGB) x 600	dot
Dot pitch	0.0675(W) x 0.2025(H)	mm
Active area	162.0(W) x 121.5(H)	mm
Module size	183.0(W) x 141.0(H) x 9.92(D)	mm
Surface treatment	Anti-Glare	
Color arrangement	RGB-stripe	
interface	LVDS	
Weight	T.B.D.	g

3. ABSOLUTE MAX. RATINGS

Item	Symbol	Values		UNIT	Note
		Min.	Max.		
Power voltage	VDD	-0.3	4	V	
	VLED	-0.3	6.0		
Operation temperature	TOP	-20	70	°C	
Storage temperature	TST	-30	80	°C	
LED Reverse Voltage	VR	-	1.2	V	each LED Note 2
LED Forward Current	IF	-	25	mA	each LED

Note 1: The absolute maximum rating values of this product are not allowed to be exceeded at any times. Should a module be used with any of the absolute maximum ratings exceeded, the characteristics of the module may not be recovered, or in an extreme case, the module may be permanently destroyed.

Note 2: VR Conditions: Zener Diode 20mA

4. ELECTRICAL CHARACTERISTICS

4-1 TFT LCD Module

		MIN	NOM	MAX	UNIT
V _{DD}	Supply voltage	3	3.3	3.6	V
V _{IH}	High-level input voltage (SHTDN)	2			V
V _{IL}	Low-level input voltage (SHTDN)			0.8	V
V _{ID}	Magnitude differential input voltage	0.1		0.6	V
V _{IC}	Common-mode input voltage	$\frac{ V_{ID} }{2}$		$2.4 - \frac{ V_{ID} }{2}$	V

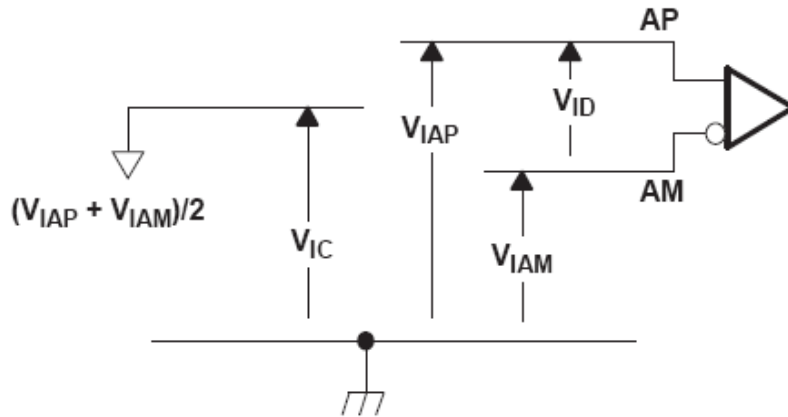

Item	Symbol	Values			Unit	Remark
		MIN	TYP	MAX		
LED Driver Power Voltage	V_{LED}	4.5	5.0	5.5	V	
LED Driver Current Consumption	I_{LED}	--	410	--	mA	$V_{LED}=5V$ $V_{ADJ}=3.3V$ (duty 100%)

4-2 Backlight Driving Conditions

Item	Symbol	Values			Unit	Note
		Min.	Typ.	Max.		
LED voltage	VL	--	9.9	10.5	V	Note 1
LED current	IL	162	180	198	mA	$T_a=25^{\circ}C$
LED life time	--	20,000	--	--	Hr	Note 2

Note 1 : The LED Supply Voltage is defined by the number of LED at $T_a=25^{\circ}C$ and $I_L=180mA$.

Note 2 : The "LED life time" is defined as the module brightness decrease to 50% original brightness at $T_a=25^{\circ}C$ and $I_L=180mA$. The LED lifetime could be decreased if operating I_L is larger than 180mA.

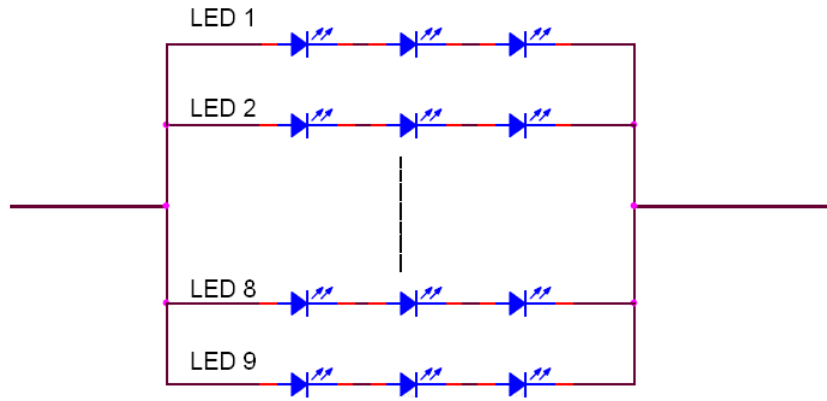

Note 3 : When LCM is operated over 40°C ambient temperature, the ILED should be follow :

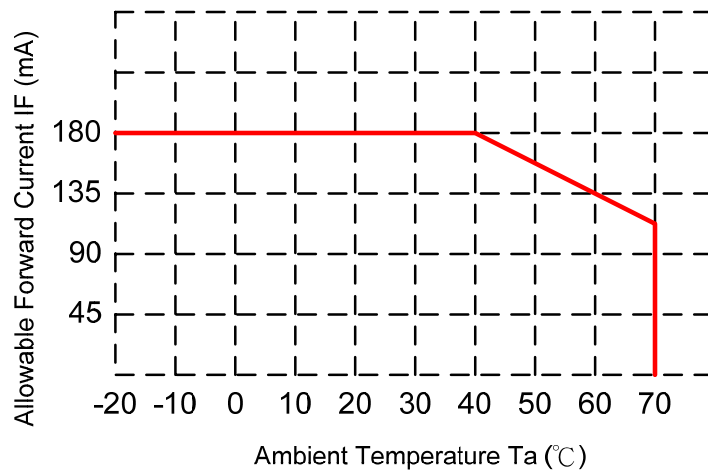

4-3 Power Sequence

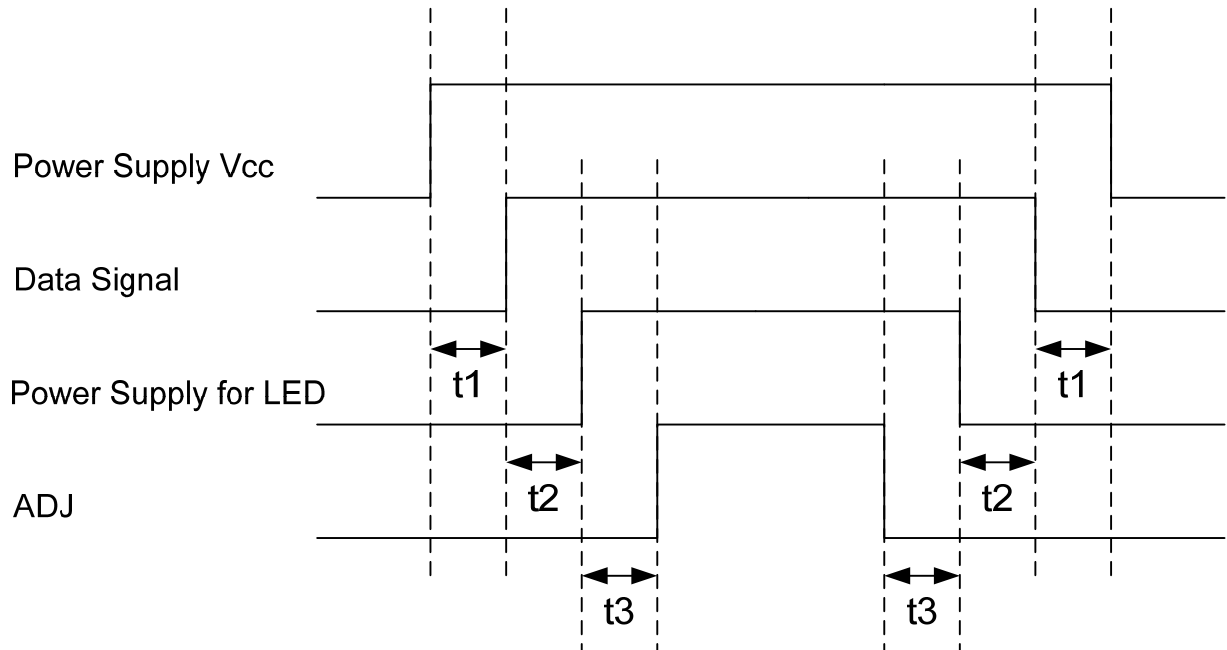

$t_1 > 50 \text{ mSec}$

$t_2 \geq 200 \text{ mSec}$

$t_3 \geq 50 \text{ mSec}$

Note : Data Signal includes DCLK, DE, HS, VS, R0~R5, G0~G5, B0~B5.

Touch Panel Electrical Specification

Item	Specifications
(1) Supply voltage	DC 5V.
(2) Loop resistance	(1)X:100~500 ohm, Y:350~850
(3) Linearity	$X \leq 1.5\%$, $Y \leq 1.5\%$
(4) Response	$\leq 15\text{ms}$
(5) Insulation Resistance	20Mohm min/25V(DC)

Item	Value	
Operation force	20-150g	
Optical Characteristics	Total Transmittance	$\geq 78\%$
	Total Haze	$\leq 7.0\%$
	Definition	$> 93\%$
Hardness	3H	
capacitance	$< 30\text{nF}$	
Operation lift	Tapping durability	1,000,000times
	Pen sliding durability	100,000times

Interface

No.	Symbol	Function
1	YU	Touch Panel Top Signal in Y Axis
2	XR	Touch Panel Right Signal in X Axis
3	YD	Touch Panel Bottom Signal in Y Axis
4	XL	Touch Panel Left Signal in X Axis

5. Optical Specifications

Item	Symbol	Condition	Values			Unit	Note
			Min.	Typ.	Max.		
Viewing angle (CR \geq 10)	θ L	$\Phi = 180^\circ$ (9 o'clock)	60	70	--	degree	Note1
	θ R	$\Phi = 0^\circ$ (3 o'clock)	60	70	--		
	θ T	$\Phi = 90^\circ$ (12 o'clock)	40	50	--		
	θ B	$\Phi = 270^\circ$ (6 o'clock)	60	70	--		
Response time	TON	Normal $\theta = \Phi = 0^\circ$	--	10	20	msec	Note3
	TOFF		--	15	30	msec	
Contrast ratio	CR		400	500	--	--	Note4
Color chromaticity	WX		0.26	0.31	0.36	--	Note5
	WY		0.28	0.33	0.38	--	Note6
Luminance	L		160	200	--	cd/m ²	Note6
Luminance uniformity	YU		70	75	--	%	Note7

Test Conditions :

1. VCC = 3.3V, IL = 180mA (Backlight current), the ambient temperature is 25°C.
2. The test systems refer to Note 2.

Note 1 : Definition of viewing angle range

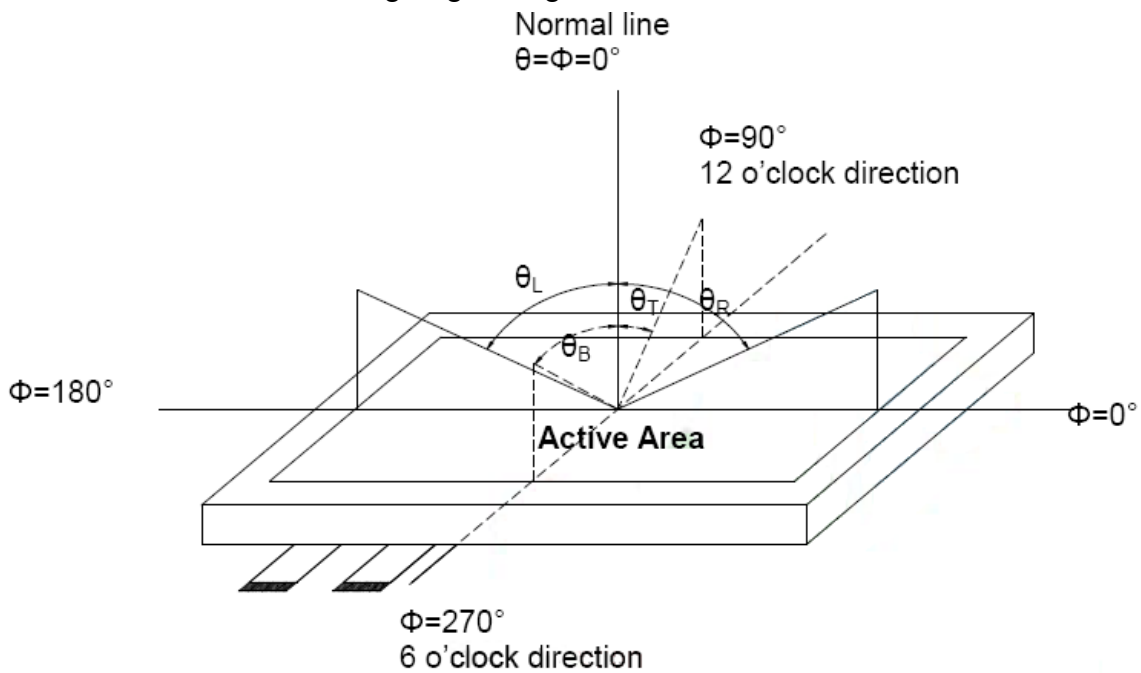

Note 2 : Definition of optical measurement system.

The optical characteristics should be measured in dark room. After 30 minutes operation, the optical properties are measured at the center point of the LCD screen. (Response time is measured by Photo detector TOPCON BM-7, other items are measured by BM-5A/Field of view : 1° / Height : 500mm.)

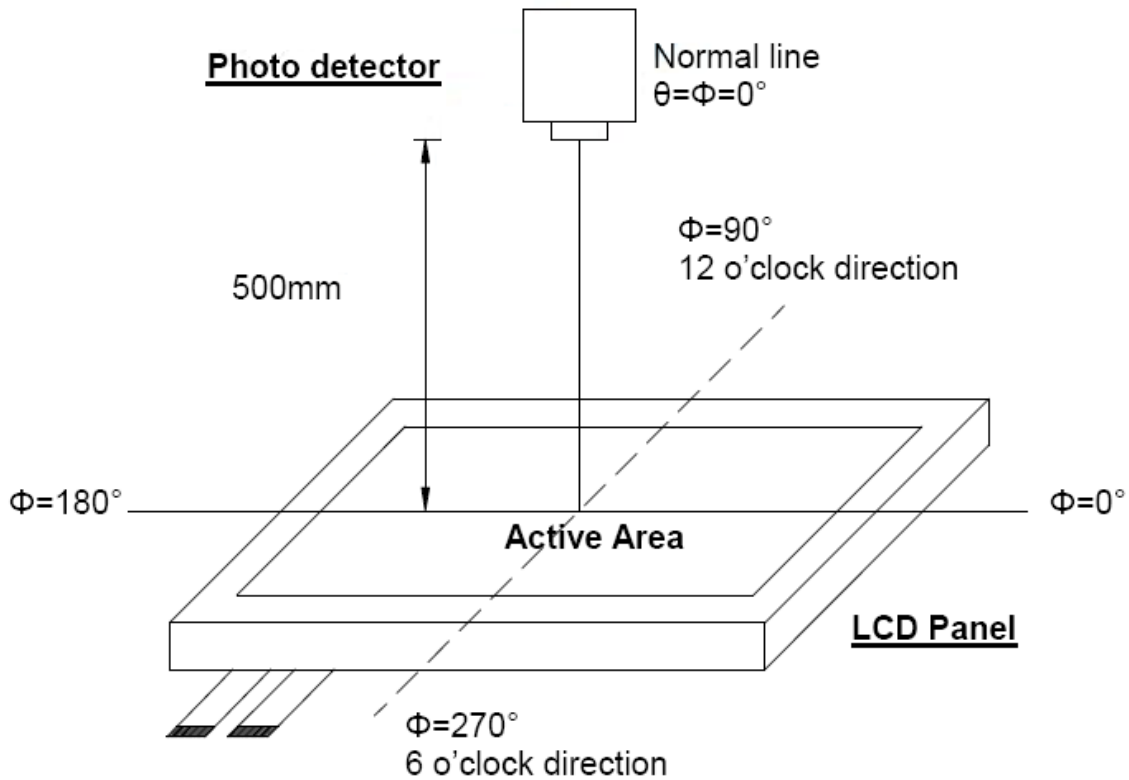

Note 3 : Definition of Response time

The response time is defined as the LCD optical switching time interval between “White” state and “Black” state. Rise time (T_{ON}) is the time between photo detector output intensity changed from 90% to 10%. And fall time (T_{OFF}) is the time between photo detector output intensity changed from 10% to 90%.

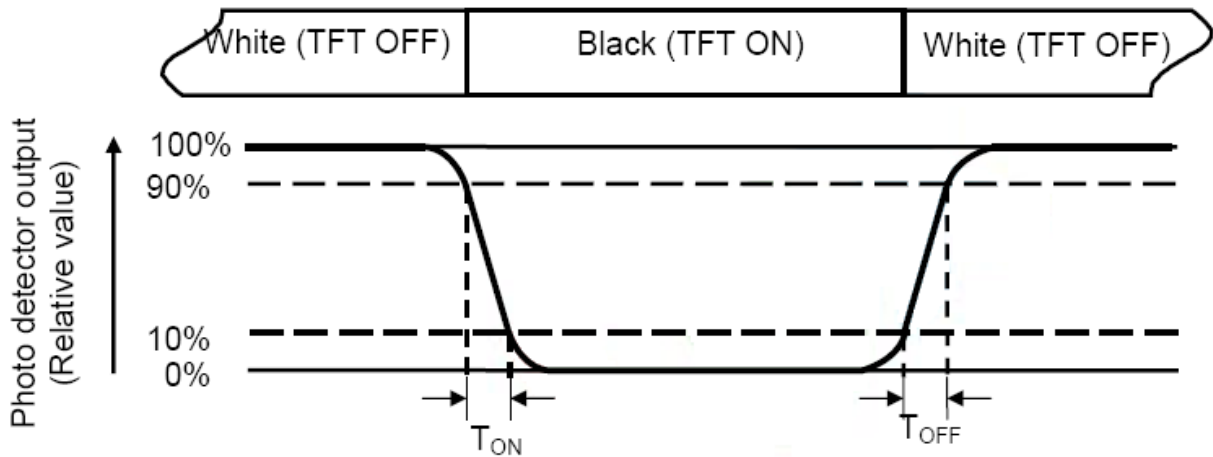

Note 4 : Definition of contrast ratio

$$\text{Contrast ratio (CR)} = \frac{\text{Luminance measured when LCD on the "White" state}}{\text{Luminance measured when LCD on the "Black" state}}$$

Note 5 : Definition of color chromaticity (CIE1931)

Color coordinated measured at center point of LCD.

Note 6 : All input terminals LCD panel must be ground when measuring the center area of the panel.

Note 7 : Definition of Luminance Uniformity

Active area is divided into 9 measuring areas (Refer to bellow figure). Every measuring point is placed at the center of each measuring area.

$$\text{Luminance Uniformity (Yu)} = \frac{B_{\min}}{B_{\max}}$$

L ----- Active area length W ----- Active area width

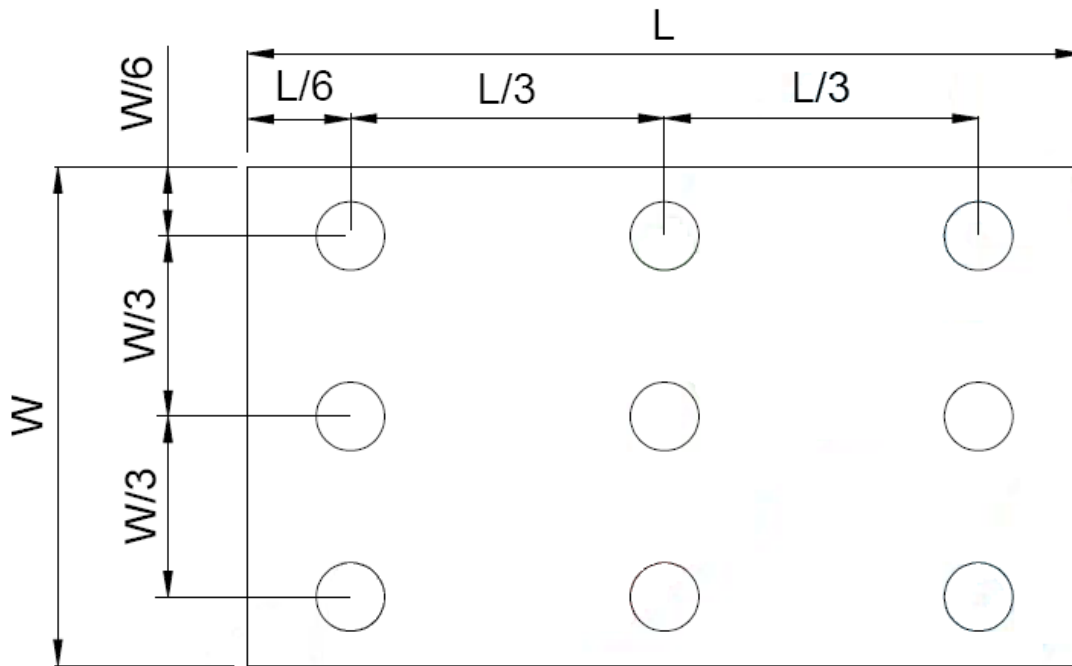

B_{\max} : The measured maximum luminance of all measurement position.

B_{\min} : The measured minimum luminance of all measurement position.

6. INTERFACE

TFT LCD Panel Driving Section

Pin No.	Symbol	Description	Note
1	VDD	POWER SUPPLY:3.3V	
2	VDD	POWER SUPPLY:3.3V	
3	GND	Power Ground	
4	GND	Power Ground	
5	IN0-	Transmission Data	
6	IN0+	Transmission Data	
7	GND	Power Ground	
8	IN1-	Transmission Data	
9	IN1+	Transmission Data	
10	GND	Power Ground	
11	IN2-	Transmission Data	
12	IN2+	Transmission Data	
13	GND	Power Ground	
14	CLK-	Sampling Clock	
15	CLK+	Sampling Clock	
16	GND	Power Ground	
17	ADJ	Adjust the LED brightness	(1)
18	NC	No connection.	
19	GND/VLED	JP7=1-2 & JP5=2-3short → power supply of LED driver circuit.	(2)
20	GND/VLED	JP7=2-3 & JP5=1-2short → GND terminal. (default setting)	

NOTE :

(1) Pin3: ADJ is PWM signal input. It is for brightness control.

ITEM	SYMBOL	MIN	TYP	MAX	UNIT
ADJ signal frequency	f_{PWM}	100	--	1K	Hz
ADJ signal logic level High	V_{IH}	2V	--	VLED (5.0V)	V
ADJ signal logic level Low	V_{IL}	0	--	0.5	V

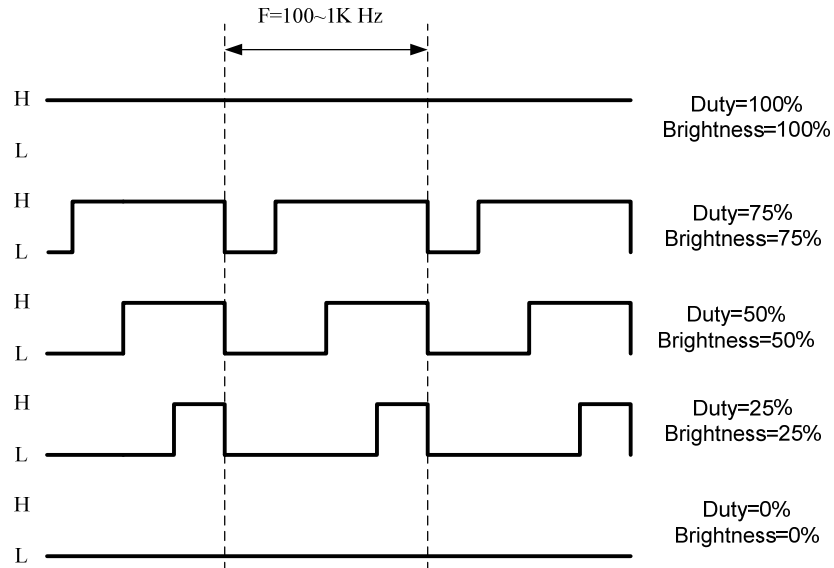

(2)

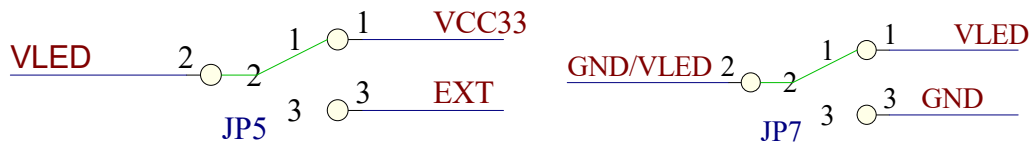

7. INPUT SIGNAL :
7-1 LVDS SIGNAL :

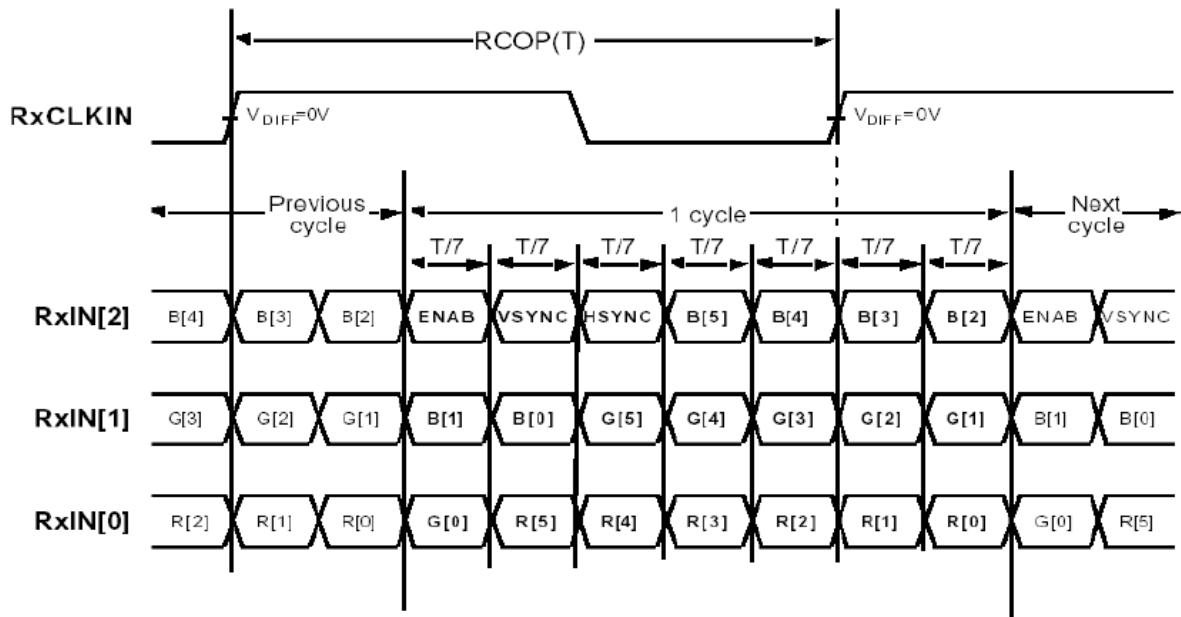

Note : R/G/B[5]s are MSBs and R/G/B[0]s are LSBs

7-2 LVDS AC Timing Diagram :

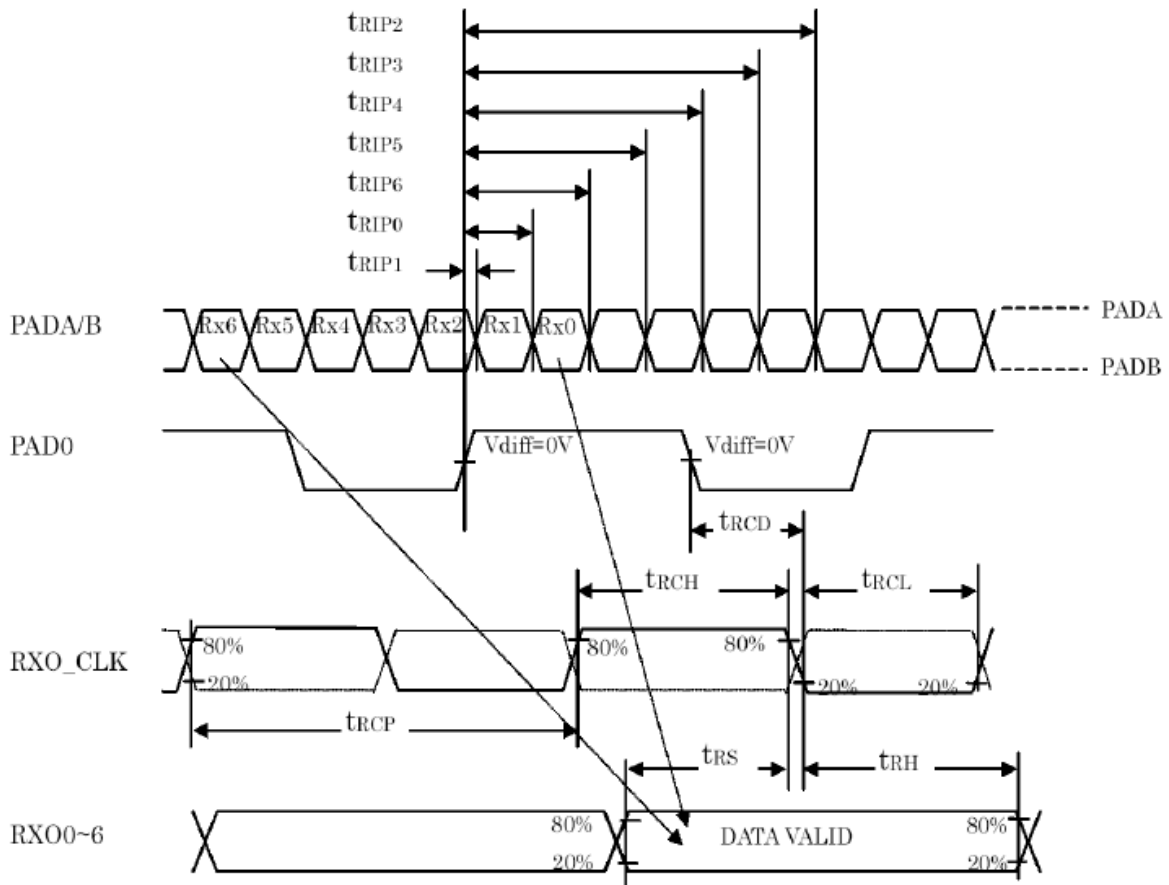

7-3 Phase Lock Loop Set Time :

(Case1)

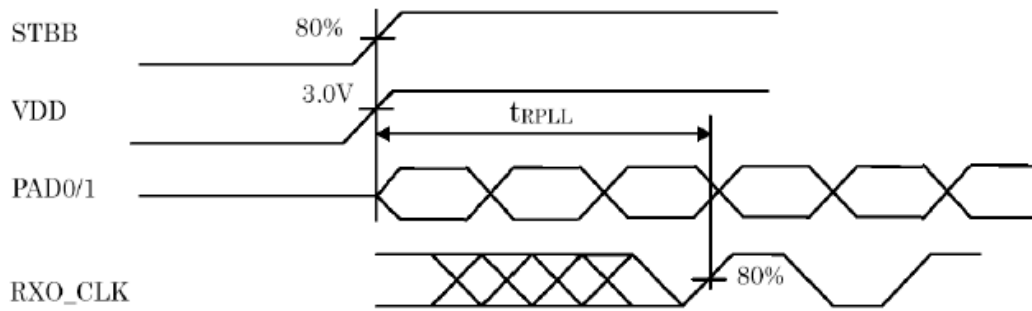

(Case2)

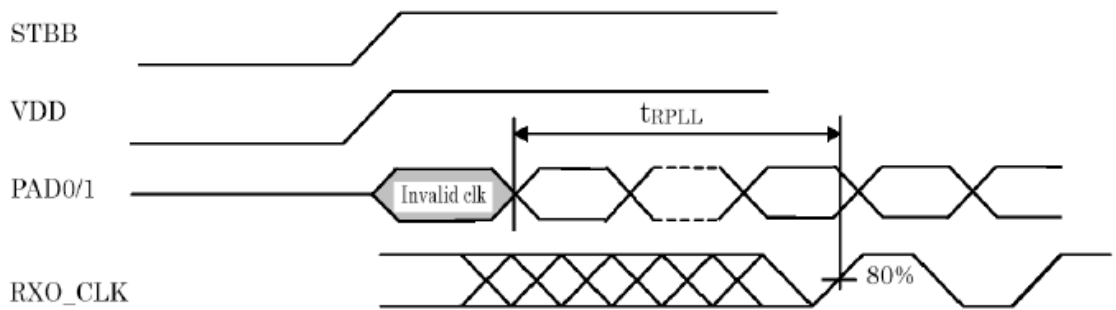

7-3 AC Electrical Characteristics

Item	Symbol	Values			Unit	Remark
		Min.	Typ.	Max.		
HS setup time	T_{hst}	8	-	-	Ns	
HS hold time	T_{hhd}	8	-	-	Ns	
VS setup time	T_{vst}	8	-	-	Ns	
VS hold time	T_{vhd}	8	-	-	Ns	
Data setup time	T_{dsu}	8	-	-	Ns	
Data hole time	T_{dhd}	8	-	-	Ns	
DE setup time	T_{esu}	8	-	-	Ns	
DE hole time	T_{ehd}	8	-	-	Ns	
VDD Power On Slew rate	T_{POR}	-	-	20	ms	
RSTB pulse width	T_{Rst}	10	-	-	us	
CLKIN cycle time	T_{coh}	20	-	-	Ns	
CLKIN pulse duty	T_{cwh}	40	50	60	%	
Output stable time	T_{sst}	-	-	6	us	

7-4 Recommended Input Timing of LVDS transmitter

Item	Symbol	Values			Unit	Remark
		Min.	Typ.	Max.		
Horizontal Display Area	thd	-	800	-	DCLK	
DCLK Frequency	fclk	-	40	50	MHz	
One Horizontal Line	th	862	1056	1200	DCLK	
HS pulse width	thpw	1	-	40	DCLK	
HS Back Porch(Blanking)	thb	46	46	46	DCLK	
HS Front Porch	thfp	16	210	354	DCLK	

Item	Symbol	Values			Unit	Remark
		Min.	Typ.	Max.		
Vertical Display Area	tvd	-	600	-	TH	
VS period time	tv	624	635	700	TH	
VS pulse width	tvpw	1	-	20	TH	
VS Back Porch(Blanking)	tvb	23	23	23	TH	
VS Front Porch	tvfp	1	12	77	TH	

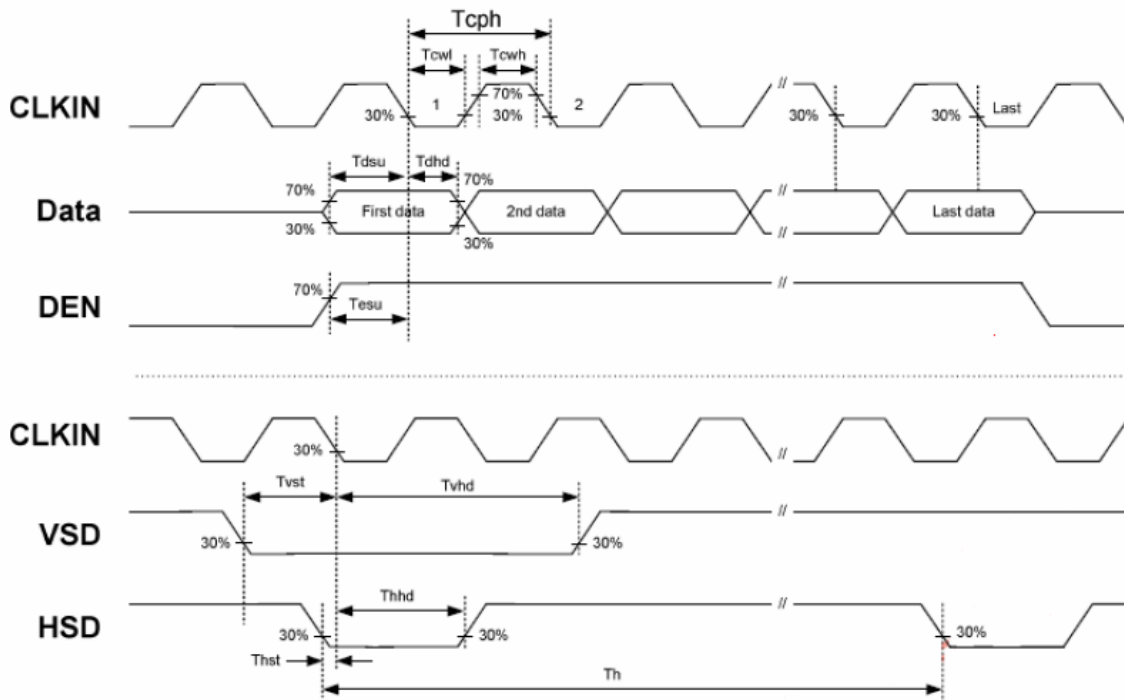

8. Reliability Test Items

Test Item	Test Conditions	Note
High Temperature Operation	70±3°C , t=240 hrs	
Low Temperature Operation	-20±3°C , t=240 hrs	
High Temperature Storage	80±3°C , t=240 hrs	1,2
Low Temperature Storage	-30±3°C , t=240 hrs	1,2
Storage at High Temperature and Humidity	40°C, 90% RH , 240 hrs	1,2
Thermal Shock Test	-20°C (30min) ~ 70°C (30min) 20 cycles	1,2
Vibration Test (Packing)	Sweep frequency : 10 ~ 55 ~ 10 Hz/1min Amplitude : 0.75mm Test direction : X.Y.Z/3 axis Duration : 30min/each axis	2

Note 1 : Condensation of water is not permitted on the module.

Note 2 : The module should be inspected after 1 hour storage in normal conditions (15-35°C , 45-65%RH).

Note 3 : The module shouldn't be tested more than one condition, and all the test conditions are independent.

Note 4 : All the reliability tests should be done without protective film on the module.

9. General Precautions

9-1 Safety

Liquid crystal is poisonous. Do not put it your mouth. If liquid crystal touches your skin or clothes, wash it off immediately by using soap and water.

9-2 Handling

1. The LCD panel is plate glass. Do not subject the panel to mechanical shock or to excessive force on its surface.
2. The polarizer attached to the display is easily damaged. Please handle it carefully to avoid scratch or other damages.
3. To avoid contamination on the display surface, do not touch the module surface with bare hands.
4. Keep a space so that the LCD panels do not touch other components.
5. Put cover board such as acrylic board on the surface of LCD panel to protect panel from damages.
6. Transparent electrodes may be disconnected if you use the LCD panel under environmental conditions where the condensation of dew occurs.
7. Do not leave module in direct sunlight to avoid malfunction of the ICs.

9-3 Static Electricity

1. Be sure to ground module before turning on power or operation module.
2. Do not apply voltage which exceeds the absolute maximum rating value.

9-4 Storage

1. Store the module in a dark room where must keep at $+25\pm 10^{\circ}\text{C}$ and 65%RH or less.
2. Do not store the module in surroundings containing organic solvent or corrosive gas.
3. Store the module in an anti-electrostatic container or bag.

9-5 Cleaning

1. Do not wipe the polarizer with dry cloth. It might cause scratch.
2. Only use a soft sloth with IPA to wipe the polarizer, other chemicals might permanent damage to the polarizer.

9-5 Others

1. AMIPRE will provide one year warrantee for all products and three months warrantee for all repairing products.
2. Do not keep the LCD at the same display pattern continually. The residual image will happen and it will damage the LCD. Please use screen saver.

